



capabilities brochure
commercial & industrial

quality products for quality water.



PRODUCTS & EQUIPMENT SUMMARY

ENV Products is committed to offering our customers an extensive line of equipment to solve water treatment problems in the most efficient and cost effective manner possible. We utilize a variety of the most current technologies for residential, commercial, institutional, and industrial applications.

ENV Products designs and manufactures a wide array of products ranging from standard catalog type equipment to custom engineered systems tailored to comply with specific customer requirements.

You will find ENV Products equipment operating around the world, treating and purifying water to enhance the quality of life or to improve a process. ENV Products's success is inspired by our experienced people, prompt service, and quality products. All of these attributes assure the ultimate in Customer Satisfaction.



WATER SOFTENERS

ENV Products Water Softeners are fabricated using field-tested designs with a proven record of reliability. Removal of calcium and magnesium compounds in water (limestone hardness) eliminates scaling in piping, process equipment, and heat exchange systems as well as greatly improving the effectiveness of cleaning and rinsing processes.

Product Scope / Features

- Flow rates between 1–1500 GPM per vessel
- FRP or steel vessel systems
- Non-code or ASME stamped vessels
- Timer or water meter based regeneration
- Numerous piping options (CS, SS, PVC, Copper)
- Multi-port valve or valve nest systems
- Skid mounted system options
- Salt recycling system options
- Hot water systems including condensate polishers

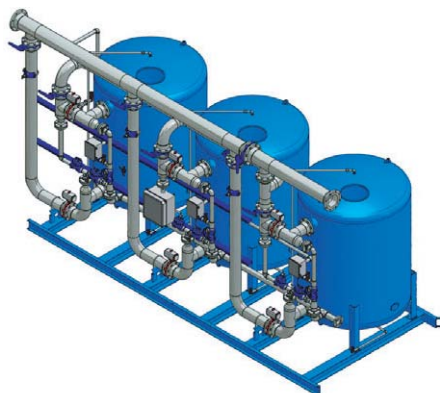

MEDIA FILTRATION

ENV Products Water Filters incorporate the latest in filter media technology to effectively handle numerous water treatment applications such as turbidity removal, taste & odor reduction, dechlorination, iron/manganese removal, and pH neutralization. Our filter systems are used frequently for reverse osmosis pre-treatment, side-stream filtration for cooling towers, process equipment protection, and drinking water improvement.

Product Scope / Features

- Flow rates between 1–1000 GPM per vessel
- FRP or steel vessel systems
- Non-code or ASME stamped vessels
- Timer or pressure drop based backwash
- Multi-port valve or valve nest systems
- Skid mounted system options
- Multi-media, activated carbon, manganese greensand and neutralization media systems.



COMMERCIAL & INDUSTRIAL

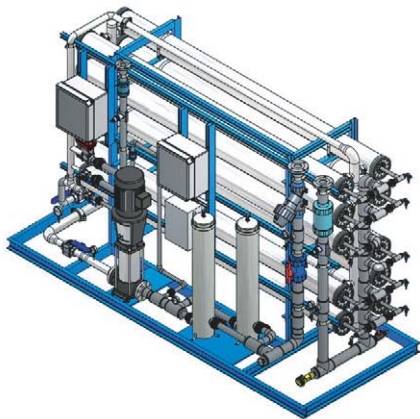

REVERSE OSMOSIS

ENV Products Commercial & Industrial Reverse Osmosis Systems are engineered to economically produce high purity water by the removal of dissolved minerals, bacteria, particles, and organic impurities. Each RO machine is constructed using the highest quality components and materials for reliable operation and exceptional performance.

Product Scope / Features

- Flow rates from 200 GPD to 300 GPM per unit
- 2.5", 4.0", and 8.0" membrane element sizes
- FRP or SS membrane element housings
- All stainless steel feed pump systems
- Membrane clean-in-place system options
- Two-pass & two-stage type system options
- Alternative membrane types including ultra filtration (UF) and nanofiltration (NF)

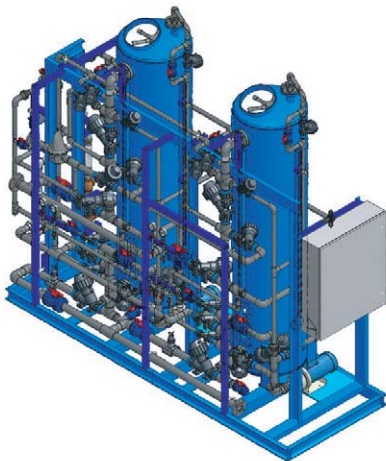

DEIONIZATION

ENV Products Deionization Systems are designed to produce ultrapure water for the more sensitive and critical applications. Each system utilizes both cation and anion polymeric ion exchange resins in either distinct vessels (Separate-Bed) or in a common vessel (Mixed-Bed). Both types of systems require acid (hydrochloric) and caustic soda (sodium hydroxide) for the automatic resin regeneration process. Systems may require turbidity, iron, or chlorine removal as pre-treatment steps depending on the water supply.

Product Scope / Features

- Flow rates between 1-500 GPM
- FRP or steel vessel systems
- Non-code or ASME stamped vessels
- Conductivity or water meter based regeneration
- PLC controlled systems as standard
- Skid mounted systems as standard
- Decarbonator system option
- Sulfuric acid based regeneration option

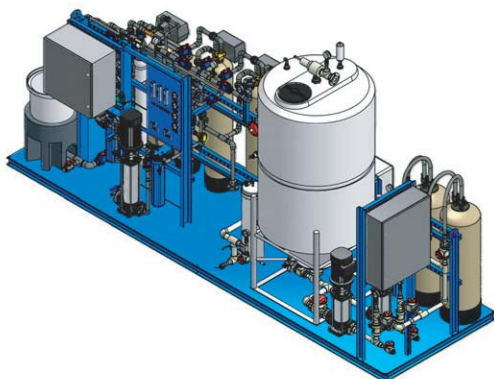

LABORATORY WATER SYSTEMS

ENV Products Laboratory Water Systems are engineered to serve as the centralized, purified water source for a variety of academic, medical, and other research laboratory facilities. Designed to meet or exceed the Type I, II, III reagent-grade water platforms set forth by CAP/NCCLS or ASTM standards. Many systems can be furnished with all the treatment equipment fully installed and factory-tested on a common skid package to minimize installation and start-up costs.

Product Scope / Features

- Pre-Treatment (inlet filter / carbon / softener)
- RO machine with storage tank
- Stainless steel distribution pumps
- DI exchange polishers
- Ultraviolet (UV) sterilizers
- Final sub-micron filter
- High purity piping (PP, SS, PVDF)
- Control Panel with Purity Monitoring



experience quality



Minneapolis, MN • ph: 952.491.0368 • fax: 952.926.0814
www.envproducts.com